

searle

KS & KM Unit Coolers



1.2 - 28 kW



SPECIFICATION

GENERAL

This range of Unit Coolers is divided into two specific designs in order to maximise the benefits available to the user, depending on the size and application of the products. The KS models cover a capacity range from 1.2-9.9 kW, whilst the KM models have a capacity range of 5.8-27.6 kW.

Both ranges have a pleasing aesthetic design, together with many technical and practical advantages, including air straightener fan guards to enhance air throw.

The KM, in addition to standard propeller fans, is also available with ducted axial fans to maximise air throw, overcome limited external pressure, or for use with air-sock distribution systems. The standard KM fan guard also allows the attachment of air socks.

All the coolers are constructed from a robust steel external casing which permits bottom lifting with the drain pan fitted, together with a unique method of positioning the drain pan once the unit has been located on the ceiling. 3 metric fin spacings are available as standard; these are 8mm, 6mm, and 4mm, assuring the users of the optimum selection whatever the application. The coolers are designed using the unique Searle 'D' fin which has been specifically developed for refrigeration applications. The 'D' fin incorporates 1/2" OD tubes with extended inner surface to maximise performance and combines the requirements of high efficiency heat transfer with the need to have secondary surface on which to deposit frost and maximise the periods between defrosts. Another major consideration in the development of this fin design was to minimise the refrigerant charge.

This range of coolers was designed with energy conservation in mind and the combined effect of the fin design, low refrigerant charge and fan and motor selection, results in a very low power requirement. The fin design minimises defrost demands - thereby reducing compressor running time.

The range is designed for use down to -40°C evaporating temperature.

CASEWORK

Fabricated galvanised sheet steel panels are assembled to form a rigid structure. The coil is supported via the coil end plates and the coil base plate through to the hanger brackets, ensuring that the coolers are mounted flush to the ceiling. This feature has the benefit of improving the hygiene standard by limiting the opportunities for growth and distribution of harmful bacteria.

External case surfaces are electrostatically painted, then baked and cured at 180 °C.

The drain pans are manufactured from galvanised sheet steel and have a slot in the back flange which permits them to sit on the rigid coil base for lifting and then dropping into an operating position once the fork lift has been removed.

The end covers have keyhole slots punched in the four corners to permit easy removal. A further benefit is that the end panels can be secured on two retaining screws during periods of internal access.

COILS

Standard (Cu/Al) coils are manufactured from 1/2" OD, copper tube (with extended inner surface) mechanically expanded into aluminium fins. The fins have metric fin spacings of 4, 6, 8mm. These equate approximately to 3, 4, 6 FPI respectively. All coils are tested to 35.8 bar and have a maximum operating pressure of 20.7 bar.

Options

- Cu/Al - Copper Tubes with Aluminium Fins
- Cu/Av - Copper Tubes with Vinyl-Coated Aluminium Fins (4mm only and not with electric defrost).
- Cu/Cu - Copper Tubes with Copper Fins (4 & 6mm only)
- Cu/ET - Copper Tubes with Electro-Tinned Copper Fins (4 & 6mm only)
- Multi-Sectioned Coils
- Coils Circuited for Glycol
- Coils Circuited for Water
- Pump Circulated Systems
- Opposite Handing to that illustrated in the dimensions tables.

Distribution System

Good refrigerant distribution is essential to achieve a maximised and stable performance from any system. The KS and KM coolers have been extensively tested to find the ideal distribution system to operate over the wide range of conditions expected.

KS10 (4, 6 & 8mm), KS15 (4, 6 & 8mm) and KS20 (6 & 8mm only) can be used with an internally equalised TEV. All other units must use externally equalised TEVs.

FANS AND MOTORS

KS Range

The KS10 and KS15 have 305mm diameter aluminium fans whilst the remainder of the range has 310mm diameter fans. These propeller fans have been specially developed to operate at peak efficiency. The blade shape was derived from combined development between Searle and its fan supplier.

The squirrel cage motors are totally enclosed air over motor rated, 70 Watt, 4 pole single phase and conform to a minimum protection rating of IP44. They are suitable for 230V-1ph-50/60Hz supply. The motors are individually wired back to a robust junction box. The cables are supported in cable trays.

KM Range

The KM range has 380mm diameter aluminium fans designed to the same rigorous standards as the KS range.

The 200 Watt squirrel cage motors are totally enclosed air over motor rated, conforming to a minimum IP44 and can be supplied for either 230V-1ph-50/60Hz, 400V-3ph-50Hz or 440V-3ph-60Hz supplies. This motor can be reconnected for use on 230V-3ph-50/60Hz. The motors have integral junction boxes and each motor is wired back to a common robust junction box.

All KM coolers are suitable for use with textile ducts. Ducting should be selected to provide a maximum pressure drop of 50 to 60 Pa. With this external resistance the reduction in air volume is approximately 35%, which will result in a 15 to 20% reduction in duty. Power inputs and currents increase by approximately 10%.

The KM range can also be supplied with aerofoil (ducted axial) fans which can be utilised to offer a choice of an extended air throw, external pressure of 120Pa or air sock distribution systems. Using these fans in free air conditions above 0°C may cause water carry-over.



SPECIFICATION

DEFROST OPTIONS

Both the KS and the KM ranges are available with many defrost options.

- KS & KM** standard electric defrost
- KS** balanced 3-phase electric defrost (except KS10 - KS 25)
- KM** heavy duty electric defrost
- KS & KM** hot gas defrost types A, B, C & D
- KS & KM** hot gas coil electric drain pan types A, B, C & D

The KS 10 to KS 25 are not available with gas defrosts. Some models with type 'A' defrost and electric pan are stocked items; all other gas defrosts will be supplied on a made-to-order basis.

ELECTRIC DEFROST KS

The KS features rear withdrawable electric heaters to permit installation in the most confined spaces. The standard electric defrost consists of 2 hairpin stainless steel heater elements. One is located in the centre of the coil, block mounted on an aluminium tray, which will evenly dissipate the heat throughout the coil. The other heater is located on the coil base plate in the drain pan. The electrical heat flux of the elements ensures a rapid defrost whilst minimising the risk of steaming. The heaters are individually wired to the terminal box located at the opposite end of the cooler to the refrigerant connections. For a balanced 3-phase supply, additional elements are fitted.

Correction Factors

(Multiply capacity by appropriate correction factor to give performance at chosen conditions)

KS/KM Cooler DT1 - WET

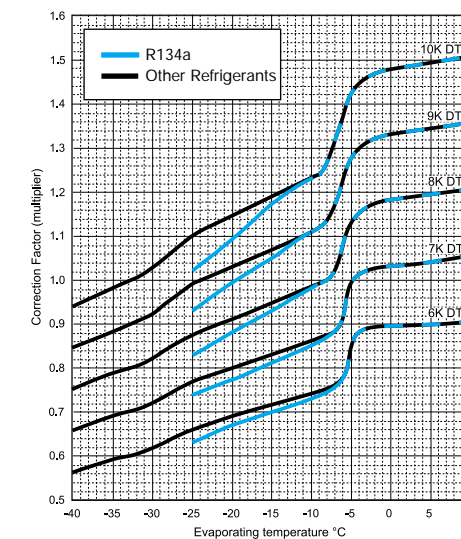

For data on other refrigerants please contact your supplier.

- * DT1 is the difference between the entering air temperature and the saturated suction temperature at the outlet of the cooler.
- ** Noise levels are based on free field conditions at a distance of 3m. Actual noise levels will depend upon cold store construction and loading. The number of coolers installed will have an effect on noise levels.
- *** Terminal air velocity 0.25m/s measured under free field conditions. Air throw cannot be considered an absolute value because many factors have a substantial effect on the distance achieved.
- † Total Power Input at Standard Condition 2 (-8°C saturated suction temperature, 0°C air entering).
- †† Not recommended above freezing.
- ‡ Unbalanced.

ELECTRIC DEFROST KM

All defrost heaters comprise stainless steel sheath elements with potted end connections with flying leads. The defrost heaters for the coil block are 'U' bend type for KM50-95 and straight heaters coupled in pairs for the KM115-175. These are all inserted directly into the fins. The drain pan heaters comprise 3 straight heaters clipped to the underside to give good thermal contact. The standard defrost is balanced across 3 phases and heavy defrost comprises additional coil block heaters to increase the total defrost load by about 40% and is unbalanced on 1 phase. Peripheral heaters are recommended on aerofoil (ducted axial) fans on applications below 0°C.

QUALITY ASSURANCE

Searle is a certified company to BS EN ISO 9001 which is a Quality Management system, including Performance Testing, Manufacturing Systems and Inspection Procedures.



RATING CONDITIONS

The duties shown in this catalogue are at EN 328 Standard Condition 2 (-8°C saturated suction temperature (dew point), 0°C air entering).

CERTIFICATION

The range is certified under the Eurovent CERTIFY-ALL direct expansion air coolers program, with performances rated in accordance with EN 328.



SPECIFICATION KS

	MODEL	CAPACITY kW 8K DTI (standard condition SC2)				AIR VOLUME m³/s	COIL DATA					
		R404A/ R507A	R134a	R407A	R407C		Total Surface Area m²	Int. volume dm³	approx. ref charge kg	CONNECTIONS		approx. dry weight kg
										INLET	OUTLET	
4mm	KS10-4	1.67	1.52	1.97	2.26	0.28	9.96	1.44	0.5	1/2"	1/2"	34
	KS15-4	2.04	1.86	2.41	2.75	0.28	9.96	1.92	0.6	1/2"	1/2"	35
	KS20-4	2.66	2.42	3.14	3.59	0.40	11.20	2.11	0.7	1/2"	5/8"	37
	KS25-4	3.44	3.13	4.06	4.64	0.38	20.54	3.74	1.2	1/2"	5/8"	45
	KS35-4	5.16	4.70	6.09	6.97	0.78	21.16	3.65	1.2	1/2"	7/8"	56
	KS40-4	6.04	5.50	7.13	8.15	0.70	31.74	5.47	1.8	1/2"	7/8"	61
	KS45-4	6.56	5.97	7.74	8.86	0.74	37.34	6.34	2.0	1/2"	7/8"	69
6mm	KS55-4	8.65	7.87	10.21	11.68	1.24	37.34	6.14	2.0	1/2"	7/8"	83
	KS70-4	9.90	9.01	11.68	13.37	1.11	56.02	9.22	3.0	5/8"	11/8"	96
	KS10-6	1.35	1.23	1.59	1.82	0.30	6.82	1.44	0.5	1/2"	1/2"	34
	KS15-6	1.71	1.56	2.02	2.31	0.30	6.82	1.92	0.6	1/2"	1/2"	34
	KS20-6	2.19	1.99	2.58	2.96	0.42	7.68	2.11	0.7	1/2"	5/8"	36
	KS25-6	3.08	2.80	3.63	4.16	0.42	14.07	3.74	1.2	1/2"	5/8"	44
	KS35-6	4.38	3.99	5.17	5.91	0.84	14.50	3.65	1.2	1/2"	7/8"	55
8mm	KS40-6	5.42	4.93	6.40	7.32	0.78	21.75	5.47	1.8	1/2"	7/8"	60
	KS45-6	5.89	5.36	6.95	7.95	0.82	25.58	6.34	2.0	1/2"	7/8"	68
	KS55-6	7.14	6.50	8.43	9.64	1.32	25.58	6.14	2.0	1/2"	7/8"	82
	KS70-6	8.75	7.96	10.33	11.81	1.23	38.38	9.22	3.0	1/2"	11/8"	93
	KS10-8	1.20	1.09	1.42	1.62	0.31	5.25	1.44	0.5	1/2"	1/2"	34
	KS15-8	1.56	1.42	1.84	2.11	0.31	5.25	1.92	0.6	1/2"	1/2"	34
	KS20-8	1.98	1.80	2.34	2.67	0.44	5.90	2.11	0.7	1/2"	5/8"	36
KS	KS25-8	2.86	2.60	3.37	3.86	0.44	10.82	3.74	1.2	1/2"	5/8"	44
	KS35-8	3.91	3.56	4.61	5.28	0.88	11.15	3.65	1.2	1/2"	7/8"	55
	KS40-8	4.95	4.50	5.84	6.68	0.82	16.73	5.47	1.8	1/2"	7/8"	60
	KS45-8	5.42	4.93	6.40	7.32	0.86	19.68	6.34	2.0	1/2"	7/8"	68
	KS55-8	6.46	5.88	7.62	8.72	1.38	19.68	6.14	2.0	1/2"	7/8"	82
	KS70-8	8.13	7.40	9.59	10.98	1.30	29.52	9.22	3.0	1/2"	11/8"	93

MODEL	No. of Fans	FAN AND MOTOR SPECIFICATIONS										ELECTRIC DEFROST						
		DIAMETER			AIR THROW		**	Motor Size	230V-1ph-50Hz			230V-1ph (400-3ph†)			400V-3ph			
		In.	nominal	mm	rpm	4mm	8mm		Noise Level	(t) Total Power	F.L.C. Amps	SC Amps	Standard		Balanced 3 phase			
		mm	mm	mm	rpm	m	dB(A)	W	Input W	Per Fan	Per Fan	Per Fan	Coil	Pan	Totals	Coil	Pan	Totals
		mm	mm	mm	rpm	m	dB(A)	W	Input W	Per Fan	Per Fan	Per Fan	kW	kW	W	kW	kW	W
KS10	1	12	305	1400	10	12	53	70	105	0.81	1.85	0.575	0.575	1.150	-	-	-	
KS15	1	12	305	1400	10	12	53	70	105	0.81	1.85	0.575	0.575	1.150	-	-	-	
KS20	1	12	310	1400	15	16	53	70	160	0.81	1.85	0.650	0.650	1.300	-	-	-	
KS25	1	12	310	1400	14	16	53	70	160	0.81	1.85	0.790	0.790	1.580	-	-	-	
KS35	2	12	310	1400	15	16	56	70	320	0.81	1.85	1.210	1.210	2.420	1.210	2.420	3.630	
KS40	2	12	310	1400	13	15	56	70	320	0.81	1.85	1.210	1.210	2.420	1.210	2.420	3.630	
KS45	2	12	310	1400	14	16	56	70	320	0.81	1.85	1.425	1.425	2.850	1.425	2.850	4.275	
KS55	3	12	310	1400	15	17	58	70	480	0.81	1.85	2.135	2.135	4.270	2.135	4.270	6.405	
KS70	3	12	310	1400	14	16	58	70	480	0.81	1.85	2.135	2.135	4.270	2.135	4.270	6.405	

SPECIFICATION KM

	MODEL	CAPACITY kW 8K DTI (standard condition SC2)				AIR VOLUME m³/s	COIL DATA					
		R404A/ R507A	R134a	R407A	R407C		Total Surface Area m²	Int. volume dm³	approx. ref charge kg	CONNECTIONS		approx. dry weight kg
										INLET	OUTLET	
4mm	KM50-4	7.34	6.68	8.66	9.9	0.85	37.81	6.70	2.1	1/2"	11/8"	85
	KM60-4	8.96	8.15	10.57	12.1	0.96	56.02	9.50	2.9	5/8"	11/8"	112
	KM80-4	12.49	11.37	14.74	16.9	1.82	50.41	8.35	2.6	5/8"	11/8"	129
	KM95-4	14.48	13.18	17.09	19.6	1.70	75.62	12.53	3.9	5/8"	11/8"	139
	KM115-4	18.75	17.06	22.13	25.3	2.73	75.62	12.24	3.8	5/8"	13/8"	170
	KM140-4	21.82	19.86	25.75	29.5	2.55	113.43	18.36	5.6	7/8"	13/8"	195
	KM175-4	27.60	25.12	32.57	37.3	3.26	134.44	21.60	6.6	7/8"	13/8"	217
6mm	KM50-6	6.35	5.78	7.49	8.6	0.91	25.90	6.70	2.1	1/2"	11/8"	83
	KM60-6	7.76	7.06	9.16	10.5	1.01	38.38	9.50	2.9	1/2"	11/8"	109
	KM80-6	10.09	9.18	11.91	13.6	1.90	34.54	8.35	2.6	1/2"	11/8"	126
	KM95-6	12.82	11.67	15.13	17.3	1.82	51.81	12.53	3.9	5/8"	11/8"	135
	KM115-6	15.26	13.89	18.01	20.6	2.85	51.81	12.24	3.8	5/8"	13/8"	166
	KM140-6	19.32	17.58	22.80	26.1	2.73	77.71	18.36	5.6	7/8"	13/8"	190
	KM175-6	24.11	21.94	28.45	32.6	3.48	92.10	21.60	6.6	7/8"	13/8"	212
8mm	KM50-8	5.78	5.26	6.82	7.8	0.93	19.93	6.70	2.1	1/2"	11/8"	84
	KM60-8	7.14	6.50	8.43	9.6	1.04	29.52	9.50	2.9	1/2"	11/8"	110
	KM80-8	9.01	8.20	10.63	12.2	1.93	26.57	8.35	2.6	1/2"	11/8"	127
	KM95-8	11.63	10.58	13.72	15.7	1.86	39.85	12.53	3.9	5/8"	11/8"	136
	KM115-8	13.54	12.32	15.98	18.3	2.89	39.85	12.24	3.8	5/8"	13/8"	167
	KM140-8	17.50	15.93	20.65	23.6	2.79	59.78	18.36	5.6	7/8"	13/8"	191
	KM175-8	21.56	19.62	25.44	29.1	3.60	70.85	21.60	6.6	7/8"	13/8"	214

MODEL	No. of Fans	FAN AND MOTOR SPECIFICATIONS													ELECTRIC DEFROST							
		DIAMETER			AIR THROW		**	Motor Size	230V-1ph-50Hz			400V-3ph			400V-3ph							
		In.	nominal	mm	rpm	4mm	8mm		Noise Level	(t) Total Power	F.L.C. Amps	SC Amps	(t) Total Power	F.L.C. Amps	SC Amps	Standard		Heavy Duty ‡				
		mm	mm	mm	rpm	m	dB(A)	W	Input W	Per Fan	Per Fan	Per Fan	Input W	Per Fan	Per Fan	Per Fan	Coil	Pan	Totals	Coil	Pan	Totals
		mm	mm	mm	rpm	m	dB(A)	W	Input W	Per Fan	Per Fan	Per Fan	W	Per Fan	Per Fan	Per Fan	W	W	W	W	W	W
KM50	1	15	380	1420	20	22	62	200	355	1.60	4.50	355	0.75	2.75	1590	795	2385	2650	795	3445		
KM60	1	15	380	1420	22	25	62	200	355	1.60	4.50	355	0.75	2.75	2400	1200	3600	4000	1200	5200		
KM80	2	15	380	1420	22	25	64	200	710	1.60	4.50	710	0.75	2.75	3180	1590	4770	5300	1590	6890		
KM95	2	15	380	1420	20	22	64	200	710	1.60	4.50	710	0.75	2.75	3180	1590	4770	5300	1590	6890		
KM115	3	15	380	1420	22	25	66	200	1065	1.60	4.50	1065	0.75	2.75	4800	2400	7200	8000	2400	10400		
KM140	3	15	380	1420	20	22	66	200	1065	1.60	4.50	1065	0.75	2.75	4800	2400	7200	8000	2400	10400		
KM175	4	15	380	1420	20	22	68	200	1420	1.60	4.50	1420	0.75	2.75	5640	2820	8460	9400	2820	12220		

DIMENSIONS KS

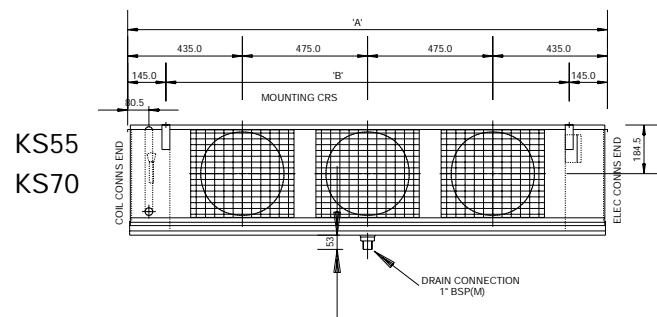
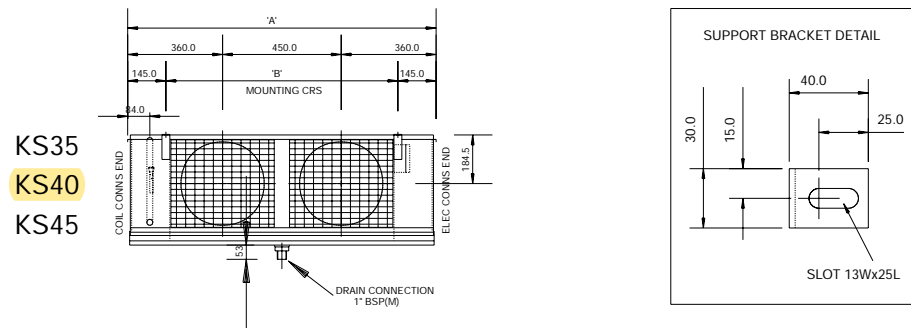
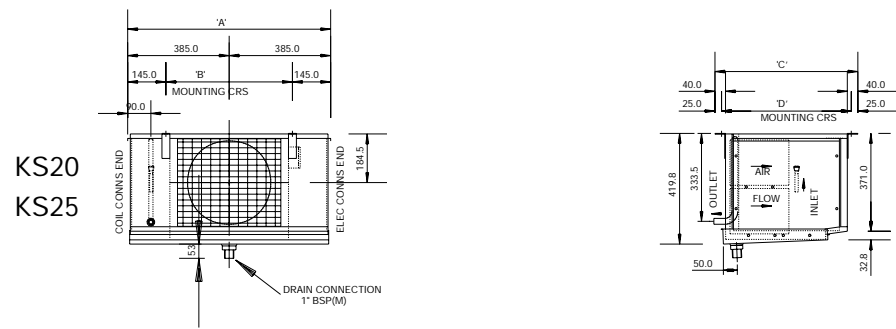
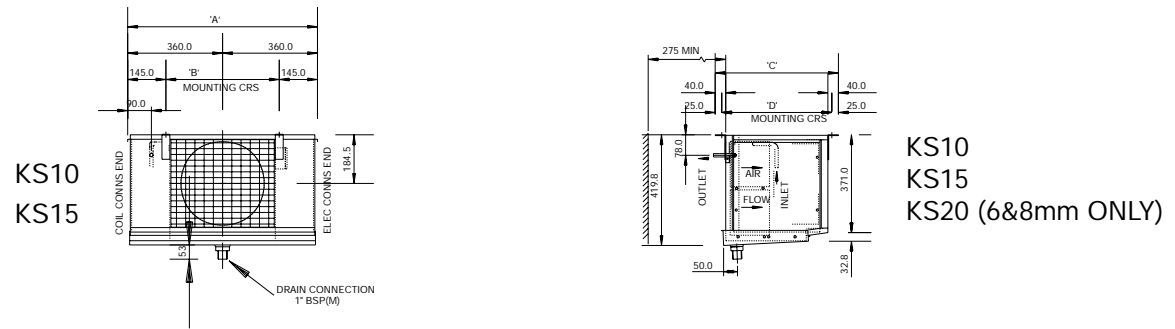

MODEL	A	B	C	D
KS10	720	430	467	417
KS15	720	430	467	417
KS20	770	480	467	417
KS25	870	580	542	492
KS35	1170	880	467	417
KS40	1170	880	542	492
KS45	1320	1030	542	492
KS55	1820	1530	467	417
KS70	1820	1530	542	492

(All dimensions in mm)

DIMENSIONS KM

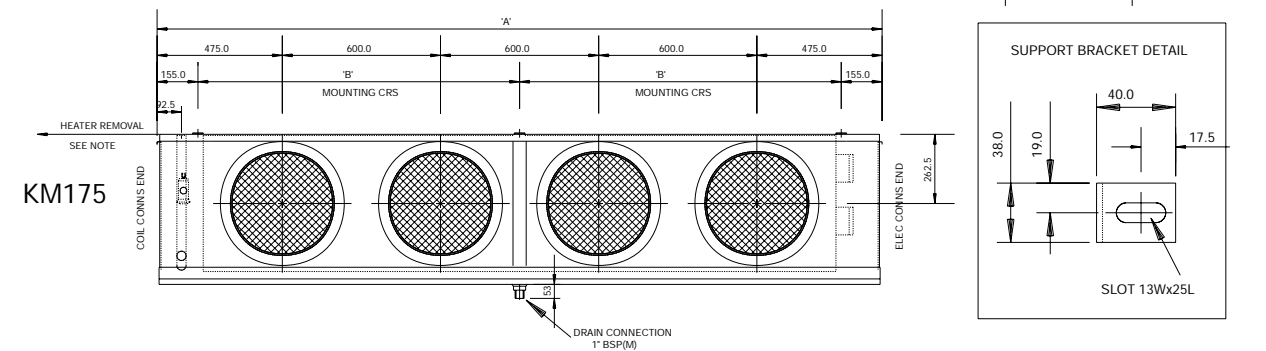
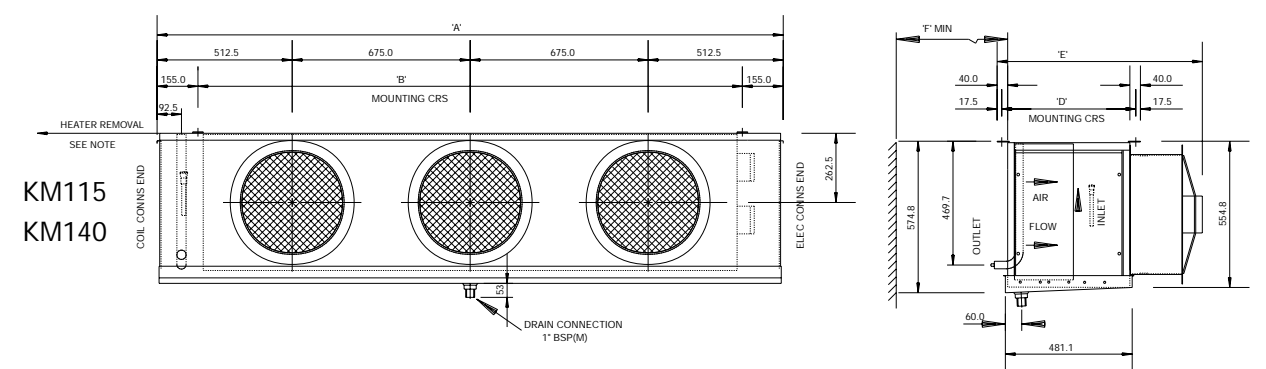
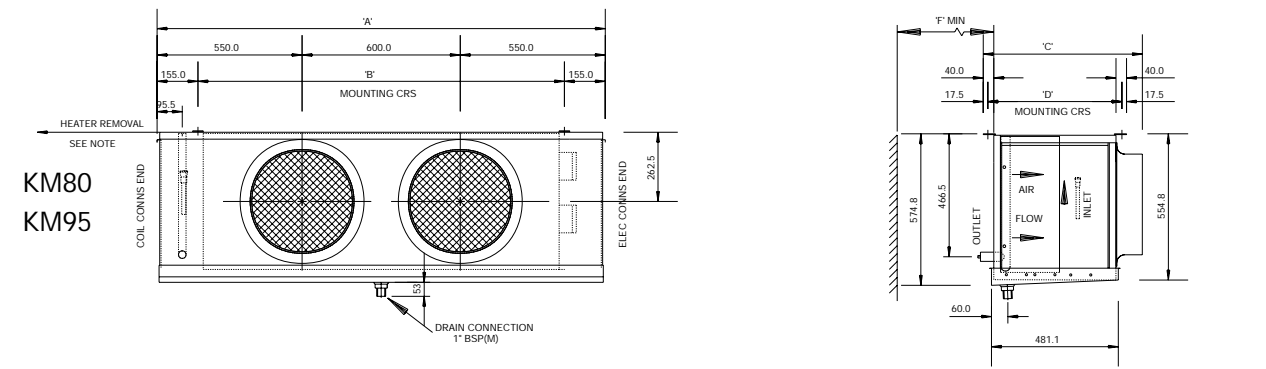
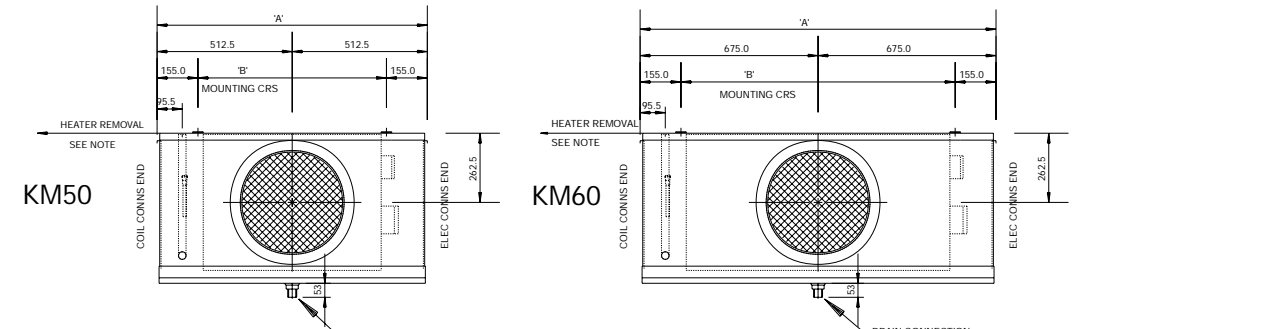

MODEL	A	B	C	D	E	F
KM50	1025	715	604	509	778	350
KM60	1350	1040	604	509	778	350
KM80	1700	1390	529	434	704	400
KM95	1700	1390	604	509	778	400
KM115	2375	2065	529	434	704	450
KM140	2375	2065	604	509	778	450
KM175	2750	2 x 1220	604	509	778	500

HEATER WITHDRAWAL	
MODEL	mm
KM50 *	805
KM60 *	1200
KM80 *	1200
KM95 *	1200
KM115	1200
KM140	1200
KM175	1200

* KM50-95: from opposite end to electrical connection only

HOW TO ORDER

KS 35 4 AV L3 1PH 60 PF F25

KM 95 8 L 380 3PH PF F25

TYPE

MODEL

FIN SPACING

4 = 4mm = (nominal 6FPI)

6 = 6mm = (nominal 4FPI)

8 = 8mm = (nominal 3FPI)

FIN MATERIAL

Blank = Aluminium

AV = Vinyl Coated Aluminium

CU = Copper

ET = Electro-tinned copper

DEFROST

Blank = Off-cycle or no defrost

L = Standard electric defrost

L2 = Heavy duty electric defrost (KM Only)

L3 = Balanced 3-phase electric defrost

HGE A = Type A hot gas coil, electric pan defrost

HGE B = Type B hot gas coil, electric pan defrost

HGE C = Type C hot gas coil, electric pan defrost

HGE D = Type D hot gas coil, electric pan defrost

HGD A = Type A hot gas coil and pan defrost

HGD B = Type B hot gas coil and pan defrost

HGD C = Type C hot gas coil and pan defrost

HGD D = Type D hot gas coil and pan defrost

MOTOR ELECTRICAL SUPPLY

1PH = 230 - 1PH (KS only)

Voltage / Phase (KM Only)

Propellor Fan / Ducted Axial Fan (KM Only)

FREQUENCY

Blank = 50 Hz

60 = 60Hz

OPTION 1

PF = Painted fans

OPTION 2

F25 = Fitted F25 thermostat

searle

Searle Manufacturing Company
Newgate Lane Fareham
Hampshire PO14 1AR UK

Telephone +44 (0)1329 823344

Facsimile +44 (0)1329 821242

Email sales@searle.co.uk

Website www.searle.co.uk